

## Conveying pump (Air Movers)

### VTRA pump

<b>Max.vacuum level</b>	: Max, -84,4kPa (-633mmHg)
<b>Max.Flow rate</b>	: 3396NI/m (203,76m³/hr)
<b>Supply air pressure</b>	: 4-6bar Max, 7bar
<b>Supply air type</b>	: Dry compressed air

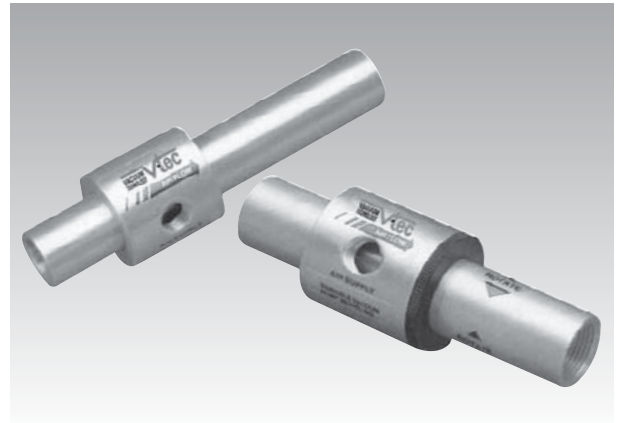

#### Main advantages

This is a series of adjustable flow rate single stage vacuum pumps particularly good for use in high contamination areas where dust and small debris is likely to enter the vacuum line. The design of this pump enables particles and small debris to pass directly through the pump. High flow rates can be achieved in conjunction with vacuum levels down to -84.4Kpa whilst maintaining a high performance to air consumption ratio.

### VTRF pump

<b>Max.vacuum level</b>	: Max, -33,8kPa (-253,5mmHg)
<b>Max.Flow rate</b>	: 4670NI/m (280,2m³/hr)
<b>Supply air pressure</b>	: 4-6bar Max, 7bar
<b>Supply air type</b>	: Dry compressed air

#### Main advantages

These pumps provide a reliable and cost effective solution for in line product transfer, particularly for transferring bulk materials, granules, continuous strips and powders. Like the VTRA the pump has a straight through design, hence they are non-clogging and maintenance free. High flows can be achieved with in line bore sizes up to 1 1/2" .

### Order no.

#### VTRA375 - AL

①

②

##### ① Vacuum pump

- VTRA 250
- VTRA 375
- VTRA 500
- VTRA 750

##### ② Material

- AL - Aluminum
- SS - Stainless steel

#### VTRF 5-6 - AL

①

②

##### ① Vacuum pump

- VTRF 2-3
- VTRF 3-3
- VTRF 5-6
- VTRF 7-6
- VTRF 15-3
- VTRF 15-6

##### ② Material

- AL - Aluminum
- SS - Stainless steel

### VTRA Air consumption vs, Vacuum level (-kPa) NI/m, 5.5bar

Model	-mmHg	126	253	380	506	633
	-kPa	16.9	33.8	50.7	67.5	84.4
VTRA250		113	170	235	275	340
VTRA375		175	325	481	594	820
VTRA500		340	623	792	934	1274
VTRA750		651	872	1245	1783	2547

### VTRA Vacuum flow vs, Vacuum level (-kPa) NI/m

Model	-mmHg	126	253	380	506	633
	-kPa	16.9	33.8	50.7	67.5	84.4
VTRA250		283	243	204	164	127
VTRA375		849	736	623	524	396
VTRA500		1698	1330	1132	991	651
VTRA750		3396	2462	1975	1443	1132

### VTRF series performance data

Model	air velocity (ft/sec)	vacuum flow (NI/m)	vacuum level (-kPa)	air consumption (NI/m)	
				2.8bar	5.5bar
VTRF2-3	490	283	27	88	170
VTRF3-3	328	424	15,2	99	170
VTRF5-6	362	849	33,8	396	679
VTRF7-6	326	1698	27	792	1358
VTRF15-3	224	4670	4,4	396	679
VTRF15-6	272	5660	8,5	792	1358

### Dimensional Information

#### VTRA Series

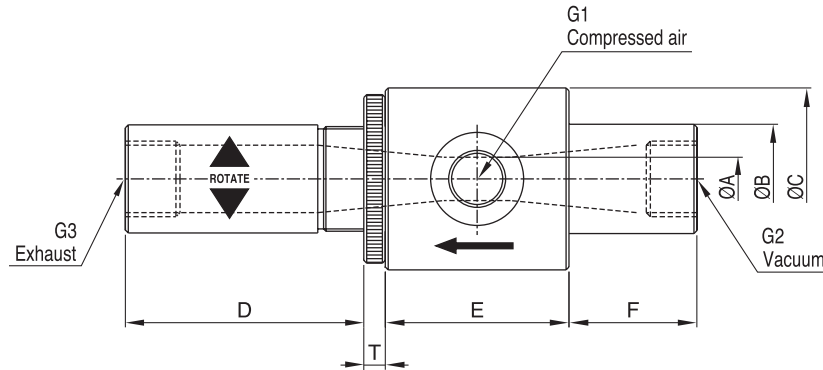

Model	Dimension									
	ØA	ØB	ØC	D	E	F	T	G1	G2	G3
VTRA250	6,8 (0,267")	18,8 (0,732")	31,3 (1,232")	41 (1,614")	31,6 (1,244")	22 (0,866")	3,7 (0,145")	G1/8"	G1/4"	G1/4"
VTRA375	9,6 (0,377")	25,2 (0,992")	43,5 (1,712")	69,8 (2,748")	44,4 (1,748")	37,6 (1,480")	5 (0,196")	G3/8"	G1/2"	G1/2"
VTRA500	12,7 (0,5")	31,4 (1,236")	50 (1,968")	63,5 (2,5")	50,8 (2")	38 (1,496")	5 (0,196")	G3/8"	G1/2"	G3/4"
VTRA750	19,1 (0,751")	37,8 (1,488")	56,8 (2,236")	85,7 (3,374")	50,8 (2")	38,2 (1,503")	5 (0,196")	G1/2"	G3/4"	G1"

#### VTRF Series

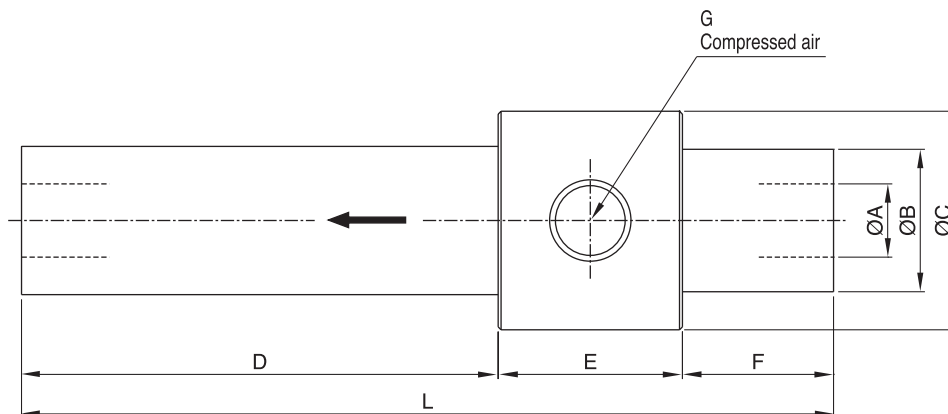

Model	Dimension							
	ØA	ØB	ØC	D	E	F	L	G
VTRF2-3	6,4 (0,252")	18,4 (0,724")	31,5 (1,240")	45 (1,771")	24,9 (0,980")	19 (0,748")	88,9 (3,5")	G1/8"
VTRF3-3	9,5 (0,374")	18,8 (0,740")	31,3 (1,232")	45,3 (1,783")	25,5 (1,003")	18,2 (0,716")	89 (3,503")	G1/8"
VTRF5-6	12,6 (0,496")	24,5 (0,964")	37,6 (1,480")	82 (3,228")	31,7 (1,248")	26 (1,023")	139,7 (5,5")	G1/4"
VTRF7-6	19 (0,748")	31,8 (1,251")	50 (1,968")	101,8 (4,007")	50,6 (1,992")	38 (1,496")	190,4 (7,496")	G3/8"
VTRF15-3	38,2 (1,503")	49,6 (1,952")	69 (2,716")	101,4 (3,992")	50,8 (2")	38,2 (1,503")	190,4 (7,496")	G3/8"

### Application

- ▶ Unloading vibrator feeders
- ▶ Reloading hoppers with plastic Regrind
- ▶ Transferring of engine valves in grinding operation
- ▶ Chip removal in drilling operation
- ▶ Transfer power detergent and caustic chemicals
- ▶ Convey peanut husks
- ▶ Selvedge removal in trimming operation
- ▶ Mandrel collection system

